



Instruction Manual

PROLAC HCPN

Hygienic Centrifugal Pump





INOXPA S.A.U.

Telers, 60
17820 - Banyoles (Spain)

hereby declare under our sole responsibility that the

Machine: **HYGIENIC CENTRIFUGAL PUMP**

Model: **PROLAC HCPN**

Type: **PROLAC HCPN 40-110, PROLAC HCPN 40-150,
PROLAC HCPN 40-205, PROLAC HCPN 50-150,
PROLAC HCPN 50-190, PROLAC HCPN 50-260,
PROLAC HCPN 65-175, PROLAC HCPN 65-215,
PROLAC HCPN 65-250, PROLAC HCPN 80-175,
PROLAC HCPN 80-205, PROLAC HCPN 80-240**

Serial number: **IXXXXXXXXXX to IXXXXXXXXXX
XXXXXXXXXXIINXXX to XXXXXXXXXXXIINXXX**

fulfils all the relevant provisions of the following directive:

Machinery Directive 2006/42/EC
Directive 2011/65/EU on the restriction of the use of certain hazardous substances in electrical and electronic equipment.
Regulation (EC) n° 1935/2004
Regulation (EC) n° 2023/2006

and with the following harmonized standards:

EN ISO 12100:2010
EN 809:1998+A1:2009/AC:2010
EN 60204-1:2018
EN ISO 14159:2008
EN 1672-2:2005+A1:2009
EN 12162:2001+A1:2009
EN IEC 63000:2018

The technical file has been prepared by the signer of this document.

David Reyero Brunet
Technical Office Manager
7th January 2026



Document: 01.032.30.05EN
Revision: (0) 2026/01



INOXPA S.A.U.

Telers, 60
17820 - Banyoles (Spain)

hereby declare under our sole responsibility that the

Machine: **HYGIENIC CENTRIFUGAL PUMP**

Model: **PROLAC HCPN**

Type: **PROLAC HCPN 40-110, PROLAC HCPN 40-150,
PROLAC HCPN 40-205, PROLAC HCPN 50-150,
PROLAC HCPN 50-190, PROLAC HCPN 50-260,
PROLAC HCPN 65-175, PROLAC HCPN 65-215,
PROLAC HCPN 65-250, PROLAC HCPN 80-175,
PROLAC HCPN 80-205, PROLAC HCPN 80-240**

Serial number: **IXXXXXXXXXX to IXXXXXXXXXX
XXXXXXXXXXIINXXX to XXXXXXXXXXXIINXXX**

fulfils all the relevant provisions of these regulations:

**Supply of Machinery (Safety) Regulations 2008
The Restriction of the Use of Certain Hazardous Substances in
Electrical and Electronic Equipment Regulations 2012 (as amended)**

and with the following designated standards:

**EN ISO 12100:2010
EN 809:1998+A1:2009/AC:2010
EN 60204-1:2018
EN ISO 14159:2008
EN 1672-2:2005+A1:2009
EN 12162:2001+A1:2009
EN IEC 63000:2018**

The technical file has been prepared by the signer of this document.

David Reyero Brunet
Technical Office Manager
7th January 2026



Document: 01.032.30.06EN
Revision: (0) 2026/01

1. Contents

1. Contents	
2. General Considerations	
2.1. Instruction manual	5
2.2. Compliance with the instructions	5
2.3. Warranty	5
3. Safety	
3.1. Warning symbols.....	6
3.2. General safety instructions	6
4. General Information	
4.1. Description	8
4.2. Application	8
5. Installation	
5.1. Delivery of the pump.....	9
5.2. Pump identification	9
5.3. Transport and storage	10
5.4. Placement	10
5.5. Pipes	11
5.6. Auxiliary system for mechanical seals	12
5.7. Electrical installation	13
6. Start-up	
6.1. Checks before starting the pump.....	14
6.2. Checks on starting the pump	14
7. Troubleshooting	
8. Maintenance	
8.1. General considerations.....	17
8.2. Checking the mechanical seal.....	17
8.3. Gasket maintenance.....	17
8.4. Tightening torque	17
8.5. Storage.....	18
8.6. Cleaning.....	18
8.7. Disassembling and assembling the pump.....	19
9. Technical Specifications	
9.1. Noise level.....	33
9.2. Weight.....	34
9.3. Dimensions	34
9.4. Exploded view and parts list for the PROLAC HCPN pump.....	36
9.5. Exploded view and parts list for PROLAC HCPN pump with double mechanical	37

2. General Considerations

2.1. INSTRUCTION MANUAL

This manual contains information on the receipt, installation, operation, assembly, dismantling and maintenance of the PROLAC HCPN centrifugal pump.

Before starting the pump, read the instructions carefully, familiarise yourself with the pump's design and operation, and follow the instructions given to the letter. These instructions should be kept in a designated location near the installation.

The information contained in the instruction manual is based on up-to-date data.

INOXPA reserves the right to amend this instruction manual without prior notice.

2.2. COMPLIANCE WITH THE INSTRUCTIONS

Failure to comply with these instructions could pose a risk to operators, the environment, equipment and facilities, and could result in the loss of the right to claim damages.

Failing to comply with these instructions could lead to the following risks in particular:

- failure of key equipment and/or plant functions,
- failures in specific maintenance and repair procedures,
- risk of electrical, mechanical and chemical hazards,
- potential environmental damage from released substances.

2.3. WARRANTY

The warranty conditions are specified in the General Terms and Conditions of Sale provided when ordering.



No modifications may be made to the equipment without first consulting the manufacturer. Use original spare parts and accessories for your own safety. The manufacturer will no longer be liable should other parts be used.

Any change to the service conditions requires written authorisation from INOXPA.

Failure to comply with the instructions set out in this manual constitutes improper use of the equipment, both from a technical and a health and safety perspective, and this releases INOXPA from all liability in the event of accidents or personal injury and/or damage to property; furthermore, any faults resulting from incorrect handling of the equipment are excluded from the warranty.

Please do not hesitate to contact us if you have any queries or require more in-depth explanations about specific data (adjustments, assembly, disassembly, and so on).

3. Safety

3.1. WARNING SYMBOLS



General warning of danger to persons and/or the pump.



Electrical hazard.

ATTENTION

Safety instructions to prevent damage to the equipment and/or its functions.

3.2. GENERAL SAFETY INSTRUCTIONS



Please read the instruction manual carefully before installing the pump and starting it up. If in doubt, please contact INOXPA.

3.2.1. During installation



Always bear in mind the [Technical Specifications of Section 9](#).

Do not start the pump before connecting it to the pipes.

Do not start the pump if the pump cover is not in place.

Check that the motor specifications are correct, particularly if there is a risk of explosion due to the working conditions.



During installation, all electrical work must be carried out by authorised personnel.

Check that the motor specifications are correct, particularly if there is a risk of explosion due to the working conditions.

3.2.2. During operation



Always bear in mind the [Technical Specifications of Section 9](#).

NEVER exceed the specified limits.

NEVER touch the pump and/or pipes during operation if the pump is being used to move hot liquids or during cleaning.

The pump contains moving parts. Never put your hands inside the pump whilst it is running.

NEVER operate with the intake and outlet valves closed.

NEVER spray the electric motor directly with water. The standard motor protection rating is IP55: protection against dust and water splashes.

3.2.3. During maintenance



Always bear in mind the [Technical Specifications of Section 9](#).

NEVER dismantle the pump before the pipes have been drained. Remember that there will always be some liquid left in the pump body (unless it has a drain). Please note that the pumped liquid may be hazardous or at high temperatures. In such cases, please consult the regulations in force in each country.

Do not leave loose parts on the floor.



ALWAYS disconnect the pump from the mains supply before carrying out any maintenance.

Remove the fuses and disconnect the cables from the motor terminals.

All electrical work must be carried out by authorised personnel.

4. General Information

4.1. DESCRIPTION

The PROLAC HCPN pump is a hygienically designed monobloc centrifugal pump.

This is a horizontally mounted, single-stage pump with a circular casing, featuring axial intake, tangential outlet and CLAMP connections. Its main components are the body, the impeller, the lantern cover and a shaft rigidly connected to the motor shaft.

The motor is a NEMA C face Premium Efficiency motor.

4.2. APPLICATION

Generally speaking, the standard version of the PROLAC HCPN range is primarily used in the food industry for the transfer of liquids.

For each type of pump, the hydraulic performance is given for various impeller diameters and at different speeds. The characteristic curves also show the power consumption and the required NPSH. The intended use of the pump is defined by its performance curve and the operating limits provided in [Technical Specifications of Section 9](#).

ATTENTION



The scope of application for each type of pump is limited. The pump was selected for specific pumping conditions at the time the order was placed. Improper use or use exceeding the specified limits may be dangerous or cause permanent damage to the equipment. INOXPA shall not be held liable for any damage that may occur if the information provided by the purchaser is incomplete (nature of the liquid, rpm, etc.).

5. Installation

5.1. DELIVERY OF THE PUMP



INOXPA cannot be held responsible for any damage to the goods caused by transport or unpacking. Check visually that the packaging is undamaged.

The following documentation is supplied with the pump:

- delivery notes,
- quick installation guide with access to the full instruction manual,
- operator's manual for the motor¹

1) if the pump has been supplied with a motor by INOXPA

Unpack the pump and check:

- the pump's intake and outlet connections, removing any remaining packaging material,

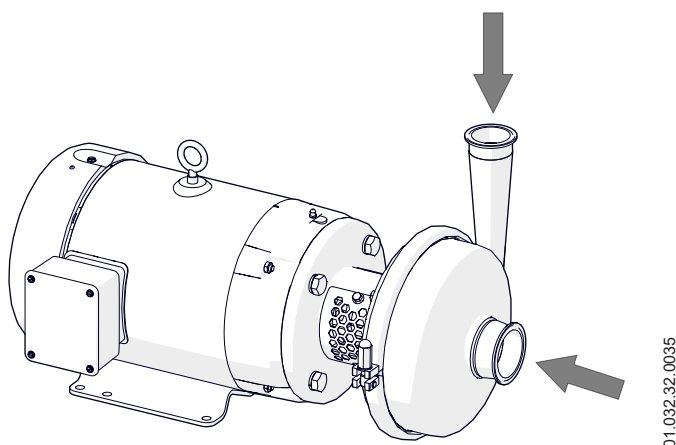

01.032.32.0035

- that the pump and motor have not been damaged,

If the pump is not in good working order and/or is missing any parts, the courier must submit a report as soon as possible.

5.2. PUMP IDENTIFICATION

Each pump has a nameplate containing the basic details needed to identify the model.



50.32.0007

5.3. TRANSPORT AND STORAGE

ATTENTION



PROLAC HCPN pumps are too heavy to be stored manually. Use a suitable means of transport. Use the points shown in the figure below to lift the pump. Only authorised personnel should transport the pump. Do not work on or walk under heavy loads.

Lift the pump as follows:

- always use two points of support, positioned as far apart as possible.

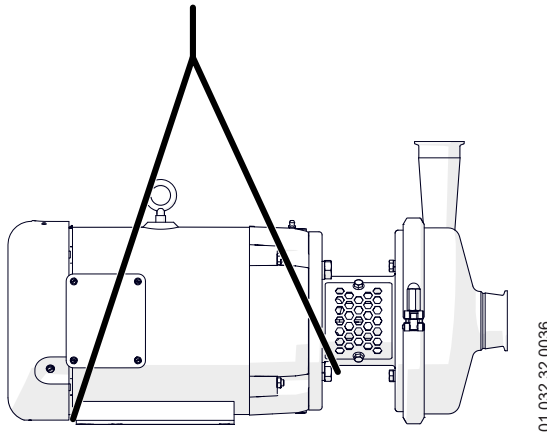

- secure the points so that they cannot slip.

See section 9. [Technical Specifications](#) for the dimensions and weights of the pump.

ATTENTION



During transport, assembly or dismantling of the pump, there is a risk of loss of stability and the pump could fall, causing damage to equipment and/or injury to operators. Make sure the pump is properly secured.

5.4. PLACEMENT

Position the pump so that there is sufficient space around it to allow access to both the pump and the motor.

Once the placement has been chosen, the pump must be installed on a flat, level surface.

ATTENTION



Install the pump so as to ensure adequate ventilation. If the pump is installed outdoors, it must be housed under a roof. It must be easily accessible for any inspection or maintenance work.

5.4.1. Extreme temperatures

Depending on the fluid being pumped, high temperatures can be generated in and around the pump.



At temperatures of 68°C or above, protective measures must be taken for staff and warnings must be displayed regarding the danger of touching the pump. The type of protection you choose must not completely insulate the pump.

5.5. PIPES

Ideal installation for maximum pump efficiency:

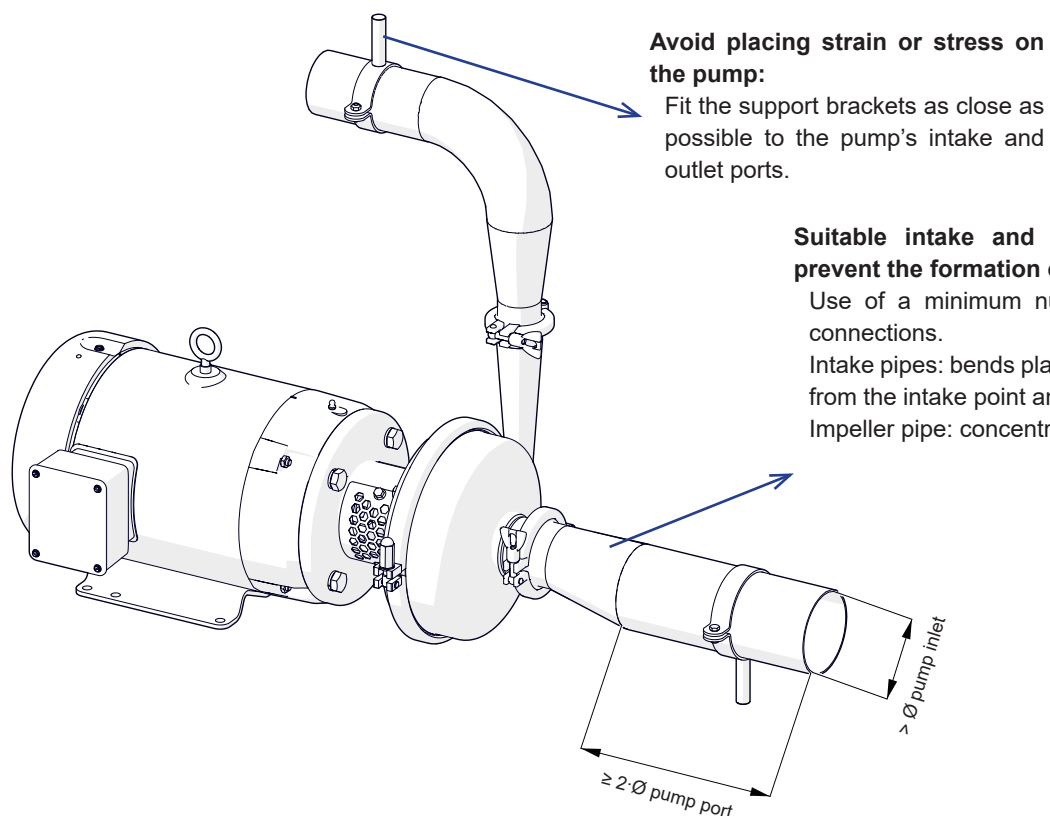

01.032.32.0037

Correct alignment of the pump with the pipework:

Pump port centre ↔ pipe centre

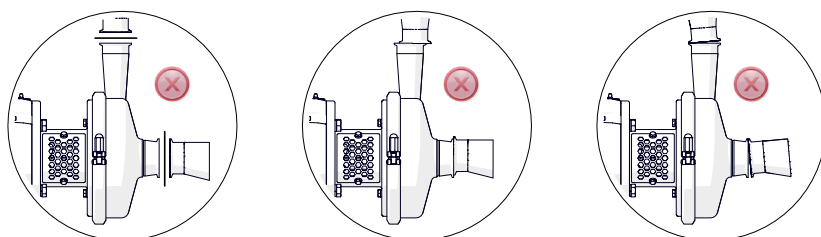

01.032.32.0038

5.5.1. Shut-off valves

The pump can be isolated for maintenance purposes. To do this, shut-off valves must be fitted to the pump's intake and outlet connections.

ATTENTION



These valves must ALWAYS be open when the pump is running.

5.6. AUXILIARY SYSTEM FOR MECHANICAL SEALS

The auxiliary system for mechanical seals can use either low-pressure external fluid (buffer fluid) or high-pressure external fluid (barrier fluid), depending on the application.

The external fluid in the auxiliary system can be supplied in an open-loop or closed-loop system. If supplied via a closed-loop system using a tank, the tank must be installed in a vertical position, within a radius of no more than 1 m from the double mechanical seal and between 1 and 2 m above it. This distance may be shorter if a recirculation pump is installed.

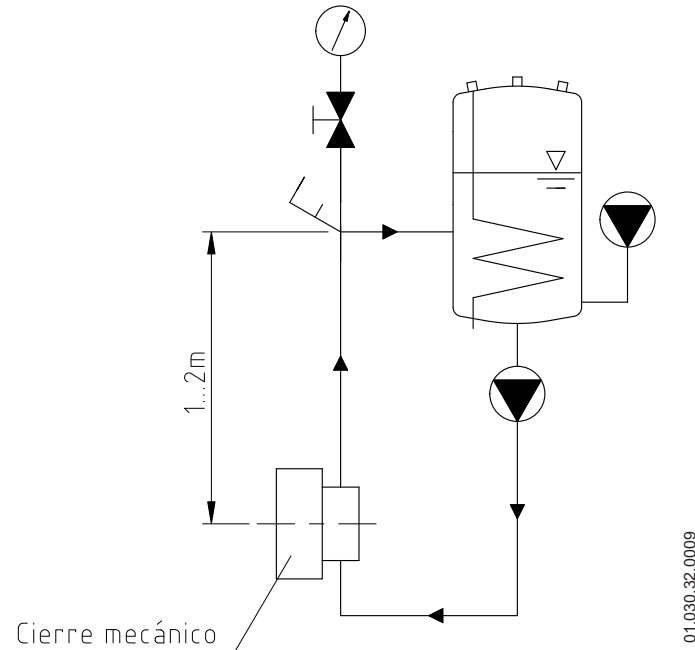

It is recommended that the auxiliary fluid pipes be made of stainless steel and be as short and straight as possible, so that the auxiliary fluid can circulate easily.

The auxiliary fluid must always enter at the bottom and exit at the top of the seal chamber to prevent the formation of preferential flow paths and to ensure that the chambers are constantly filled with product.

Check the fluid level regularly. A change in the fluid level may indicate a leak in the double mechanical seal or in the auxiliary system circuit.

In addition to requiring its own preventive maintenance, the auxiliary fluid must be drained and replaced after every failure or replacement of the seal.

The choice of auxiliary fluid is always the responsibility of the end user. INOXPA are not liable for the choice of auxiliary fluid.



ATTENTION

The auxiliary fluid for mechanical seals must circulate whenever the pump is running.

5.6.1. Buffer fluid and barrier fluid

The double mechanical seal allows operation with both low-pressure buffer fluid and high-pressure barrier fluid.

When operating at low pressure (buffer fluid), the pressure must be lower than the pressure inside the pump.

When operating at high pressure (barrier fluid), maintaining the auxiliary fluid at a pressure 100 kPa (1 bar) higher than the pressure inside the pump is recommended.

In both cases, care must be taken not to exceed the maximum pressure permitted for the double mechanical seal.

The minimum flow rate of the auxiliary fluid must be 30 l/h in both cases.

When installing the closed-loop pressurisation system, it is recommended that you follow the tank manufacturer's instructions.

To maximise the service life of the double mechanical seal, it is important that the auxiliary fluid is filtered and free from impurities. Furthermore, it must be chemically compatible with the pumped product to prevent any undesirable reactions in the event of accidental mixing, and with the materials of the mechanical seal to avoid damaging it.

ATTENTION



The auxiliary fluid must be chemically compatible with the fluids being pumped and with the materials of the double mechanical seal.

5.7. ELECTRICAL INSTALLATION



The connection of electric motors must be carried out by qualified personnel. Take the necessary steps to prevent any damage to connections and cables.



Both electrical equipment and the control system terminals and components may still carry an electrical charge even when switched off. Contact with them may endanger the safety of operators or cause irreparable damage to the equipment. Before handling the pump, ensure that the motor has stopped.

To carry out the electrical installation:

- connect the motor in accordance with the instructions provided by the motor manufacturer and in compliance with national legislation and standard EN 60204-1,
- check the direction of rotation (see the label on the pump), start and stop the motor briefly. Ensure, when viewing the pump from the rear, that the motor fan rotates clockwise.

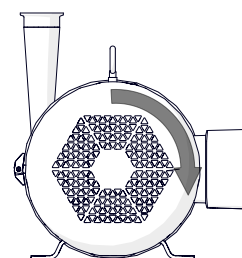

01.032.32.0039

ATTENTION



See the information label on the pump.
ALWAYS check the direction of rotation of the motor whilst there is liquid inside the pump.

6. Start-up



Before starting the pump, please read the instructions in section 5. [Installation](#) carefully. Please read section 9. [Technical Specifications](#) carefully. INOXPA cannot be held liable for any misuse of the equipment.



NEVER touch the pump or the pipes if high-temperature liquids are being pumped.

6.1. CHECKS BEFORE STARTING THE PUMP

Before starting the pump:

- fully open the shut-off valves on the intake and outlet pipes,
- if the liquid does not flow towards the pump, fill it with the liquid to be pumped,
- in the case of pumps fitted with a double mechanical seal, ensure that the auxiliary fluid is circulating correctly,

ATTENTION



The pump must NEVER run dry. Ensure that the auxiliary fluid circulates properly in pumps fitted with a double mechanical seal.

- check that the power supply matches the power rating stated on the motor data plate,
- check that the rotation direction of the motor is correct.

6.2. CHECKS ON STARTING THE PUMP

On starting the pump, check the following:

- that the pump isn't making any strange noises,
- if the absolute inlet pressure is sufficient to prevent cavitation in the pump. See the curve for the minimum required pressure above vapour pressure (NPSHr),
- the outlet pressure,
- that there are no leaks around the sealing areas.

ATTENTION



A shut-off valve must not be used in the intake pipe to regulate the flow rate. These must be kept fully open during operation.

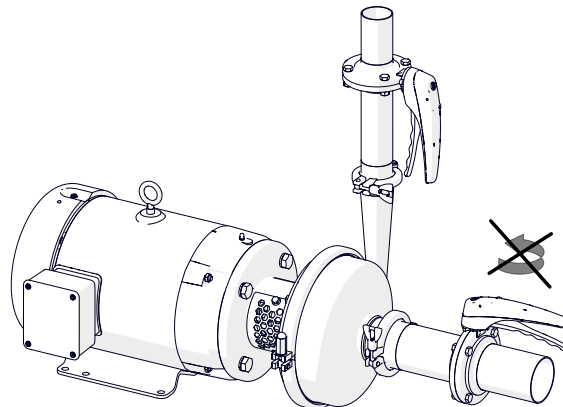

01.032.32.0040

**ATTENTION**

Monitor the motor's power consumption to prevent electrical overload.

To reduce the flow rate and the power consumed by the motor:

- regulate the flow rate at the pump outlet,
- reduce the motor speed.



Wear suitable personal protective equipment when the sound pressure level in the operating area exceeds 85 dB(A).

7. Troubleshooting

The table below provides solutions to problems that may arise during pump operation, assuming that the pump has been correctly installed and selected for the application. Please contact INOXPA if you require technical support.

Motor overload																																	
The pump has insufficient flow or pressure																																	
There is no pressure on the output side																																	
Irregular output flow or pressure																																	
Noise and vibrations																																	
The pump gets clogged																																	
Pump overheating																																	
Abnormal wear																																	
Leak from the mechanical seal																																	
	<table border="1"> <thead> <tr> <th>POSSIBLE CAUSES</th> <th>SOLUTIONS</th> </tr> </thead> <tbody> <tr> <td>Incorrect rotation direction</td> <td>- Reverse the rotation direction</td> </tr> <tr> <td>Insufficient NPSH</td> <td>- Raise the suction tank. - Lower the pump. - Reduce the vapour pressure - Increase the diameter of the intake pipe - Shorten and simplify the intake pipework</td> </tr> <tr> <td>Pump not drained</td> <td>- Drain or fill</td> </tr> <tr> <td>Cavitation</td> <td>- Increase the intake pressure</td> </tr> <tr> <td>The pump draws in air</td> <td>- Check the intake pipe and all its connections</td> </tr> <tr> <td>Blocked intake Pipe</td> <td>- Check the intake pipe and any filters.</td> </tr> <tr> <td>Pumping pressure too high</td> <td>- If necessary, reduce load losses, for example by increasing the pipe diameter.</td> </tr> <tr> <td>Flow rate too high</td> <td>- Reducing the flow rate using a diaphragm - Partially close the outlet valve. - Trim the impeller - Reduce speed</td> </tr> <tr> <td>The fluid is too viscous</td> <td>- Reduce the viscosity, by heating the fluid for example</td> </tr> <tr> <td>Fluid temperature too high</td> <td>- Lower the temperature by cooling the liquid</td> </tr> <tr> <td>Damaged or worn mechanical seal</td> <td>- Replace the seal</td> </tr> <tr> <td>O-rings incompatible with the fluid</td> <td>- Fit the correct O-rings after consulting the supplier</td> </tr> <tr> <td>The impeller is rubbing</td> <td>- Reduce the temperature - Reduce the intake pressure - Adjust the impeller/cover clearance</td> </tr> <tr> <td>Stress in the pipes</td> <td>- Connect the pipes to the pump without applying pressure</td> </tr> <tr> <td>Foreign bodies in the fluid</td> <td>- Fit a filter on the intake pipe</td> </tr> </tbody> </table>	POSSIBLE CAUSES	SOLUTIONS	Incorrect rotation direction	- Reverse the rotation direction	Insufficient NPSH	- Raise the suction tank. - Lower the pump. - Reduce the vapour pressure - Increase the diameter of the intake pipe - Shorten and simplify the intake pipework	Pump not drained	- Drain or fill	Cavitation	- Increase the intake pressure	The pump draws in air	- Check the intake pipe and all its connections	Blocked intake Pipe	- Check the intake pipe and any filters.	Pumping pressure too high	- If necessary, reduce load losses, for example by increasing the pipe diameter.	Flow rate too high	- Reducing the flow rate using a diaphragm - Partially close the outlet valve. - Trim the impeller - Reduce speed	The fluid is too viscous	- Reduce the viscosity, by heating the fluid for example	Fluid temperature too high	- Lower the temperature by cooling the liquid	Damaged or worn mechanical seal	- Replace the seal	O-rings incompatible with the fluid	- Fit the correct O-rings after consulting the supplier	The impeller is rubbing	- Reduce the temperature - Reduce the intake pressure - Adjust the impeller/cover clearance	Stress in the pipes	- Connect the pipes to the pump without applying pressure	Foreign bodies in the fluid	- Fit a filter on the intake pipe
POSSIBLE CAUSES	SOLUTIONS																																
Incorrect rotation direction	- Reverse the rotation direction																																
Insufficient NPSH	- Raise the suction tank. - Lower the pump. - Reduce the vapour pressure - Increase the diameter of the intake pipe - Shorten and simplify the intake pipework																																
Pump not drained	- Drain or fill																																
Cavitation	- Increase the intake pressure																																
The pump draws in air	- Check the intake pipe and all its connections																																
Blocked intake Pipe	- Check the intake pipe and any filters.																																
Pumping pressure too high	- If necessary, reduce load losses, for example by increasing the pipe diameter.																																
Flow rate too high	- Reducing the flow rate using a diaphragm - Partially close the outlet valve. - Trim the impeller - Reduce speed																																
The fluid is too viscous	- Reduce the viscosity, by heating the fluid for example																																
Fluid temperature too high	- Lower the temperature by cooling the liquid																																
Damaged or worn mechanical seal	- Replace the seal																																
O-rings incompatible with the fluid	- Fit the correct O-rings after consulting the supplier																																
The impeller is rubbing	- Reduce the temperature - Reduce the intake pressure - Adjust the impeller/cover clearance																																
Stress in the pipes	- Connect the pipes to the pump without applying pressure																																
Foreign bodies in the fluid	- Fit a filter on the intake pipe																																

8. Maintenance

8.1. GENERAL CONSIDERATIONS

Like any other machine, this pump requires maintenance. The instructions in this manual cover the identification and replacement of spare parts. These instructions have been prepared for maintenance staff and for those responsible for supplying spare parts.



Read the [9. Technical Specifications](#) section carefully. Maintenance work may only be carried out by persons who are suitably qualified, trained and equipped, and who have the necessary resources to carry out such work. Any parts or materials that are replaced must be disposed of or recycled in accordance with the applicable local regulations.



ALWAYS switch off the pump before carrying out any maintenance work.



This symbol indicates that the product should not be disposed of as unsorted waste but should be taken to a recycling centre for recovery and recycling.

8.2. CHECKING THE MECHANICAL SEAL

Check regularly for leaks around the shaft. If there are any leaks through the mechanical seal, replace the seal in accordance with the instructions provided in section [8.7. Dismantling and Assembling the Pump](#).

8.3. GASKET MAINTENANCE

GASKET REPLACEMENT

Preventive maintenance	Replace after 12 months. It is also recommended that gaskets are replaced when the mechanical seal is changed.
Maintenance following a leak	Replace them at the end of the process.
Scheduled maintenance	Check regularly for leaks and ensure the pump is working properly. Keep a record of the pump's maintenance. Use statistics to plan inspections.
Lubrication	During assembly, lubricate the gaskets with soapy water or a food-grade oil that is compatible with the gasket material.

The interval between each preventive maintenance service may vary depending on the pump's operating conditions: temperature, flow rate, number of operating hours per day, cleaning solution used, etc.

8.4. TIGHTENING TORQUE

Size	Nm	lbf·ft
M6	10	7
M8	21	16
M10	42	31
M12	74	55
M16	112	83

8.5. STORAGE

Before storing the pump, ensure that it is completely drained of all liquid. Avoid exposing the parts to excessively damp environments wherever possible.

8.6. CLEANING



The use of harsh cleaning products such as caustic soda and nitric acid can cause skin burns.

Wear rubber gloves when cleaning.

Always wear safety goggles.

8.6.1. CIP (clean-in-place) cleaning

If the pump is installed in a system that has a CIP process, it does not need to be dismantled.

If an automatic cleaning cycle is not scheduled, remove the pump as described in section [8.7. Dismantling and Assembling the Pump](#).

Two types of solutions can be used for CIP processes:

a. alkaline solution: 1% by weight of caustic soda (NaOH) at 70°C (150°F). To prepare this cleaning solution:

1 kg NaOH + 100 l H₂O¹ = cleaning solution

2.2 l NaOH at 33% + 100 l H₂O = cleaning solution

b. acidic solution: 0.5% by weight of nitric acid (HNO₃) at 70°C (150°F). To prepare this cleaning solution:

0.7 l HNO₃ at 53% + 100 l H₂O = cleaning solution

1) Use only chlorine-free water to prepare cleaning solutions

ATTENTION



Monitor the concentration of cleaning solutions. An incorrect concentration could cause deterioration of the pump's seals.

ALWAYS rinse thoroughly with clean water at the end of the cleaning process to remove any traces of the cleaning product.

8.6.2. Automatic SIP (sterilisation-in-place)

The steam sterilisation process is applied to all equipment, including the pump.

ATTENTION

DO NOT switch on the equipment during the steam sterilisation process.

The components and materials will not be damaged if the instructions in this manual are followed.

No cold liquid may be introduced until the temperature of the equipment has fallen below 60°C (140°F).



The pump generates a significant pressure drop throughout the sterilisation process. Using a bypass circuit from a discharge valve to ensure the steam or superheated water sterilises the entire circuit is recommended.

Maximum conditions during the SIP process with steam or superheated water:

- a. maximum temperature: 140°C / 284°F
- b. maximum time: 30 min
- c. cooling: sterilised air or inert gas
- d. materials: EPDM (recommended)
FPM (use with care)

8.7. DISASSEMBLING AND ASSEMBLING THE PUMP

The assembly and dismantling of the pumps must only be carried out by qualified personnel. You must ensure that staff read this instruction manual carefully, paying particular attention to the instructions relating to the work they are going to carry out.

ATTENTION



Incorrect assembly or dismantling can cause damage to the pump's operation, leading to high repair costs and prolonged downtime.

INOXPA accepts no liability for accidents or damage resulting from failure to follow the instructions contained in this manual.

Preparation

Ensure the work area is clean, as some components, including the mechanical seal, may require careful handling, whilst others have low tolerances.

Check that the parts being used have not been damaged during transport. To do this, you need to check the mating surfaces, the alignment of the surfaces, the seal, the presence of burrs, etc.

After each dismantling, clean the parts thoroughly and check for any damage. Replace all damaged parts.

Tools

Use the correct tools for assembly and dismantling operations.

Cleaning

Before dismantling the pump, clean both the inside and outside.

8.7.1. Pump with a single mechanical seal

Disassembling

1. Loosen and remove the retaining ring (15) and remove the pump body (01).
2. Remove the O-ring (80) from the pump cover (03). Check its condition and replace it if it is damaged.

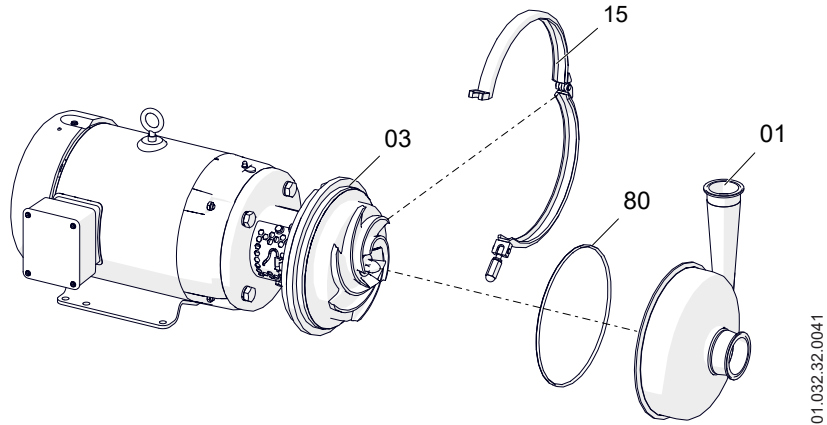

3. Remove the lantern guards (47) by loosening and removing the flanged screws (50).

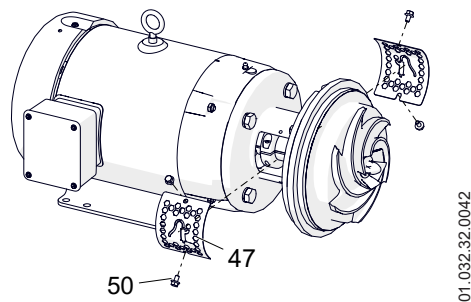

4. Secure the shaft (05) by placing a spanner between the flanges to remove the impeller nut (45)
5. Remove the O-ring (80A) from the impeller nut (45).
6. Remove the impeller (02). If necessary, give it a sharp tap with a rubber mallet to knock the cone loose.
7. Remove the rotating part of the mechanical seal (08) from the rear of the impeller (02).
8. Remove the stationary part of the mechanical seal (08) from the pump cover (03).

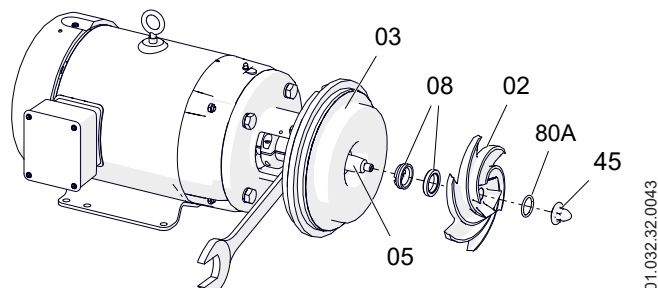

9. Loosen and remove the screws (52) and washers (53) securing the pump cover (03) to the housing (04).
10. Loosen and remove the Allen screws (51) securing the mechanical seal cover (09) to the pump cover (03).
11. Remove the thrust washer and spring from the mechanical seal (08) on the mechanical seal cover (09).

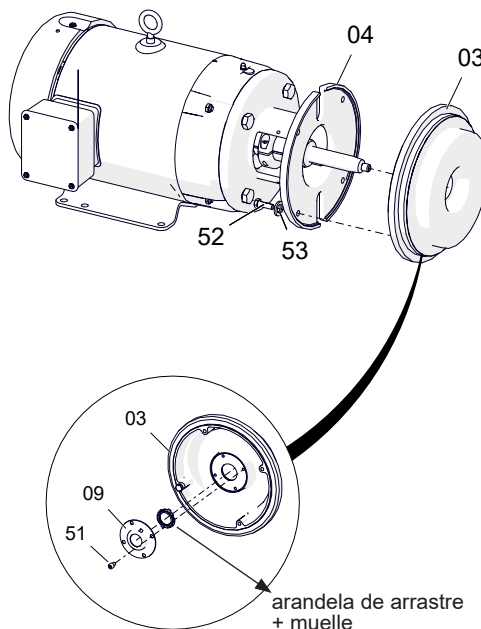

12. Remove the lantern ring (04) from the motor (93) by loosening and removing the screws (52A) and their washers (53A).
13. Loosen the Allen screws (51E) on the axle clamping ring (17).
14. Remove the pump shaft (05) together with the shaft retaining ring (17).

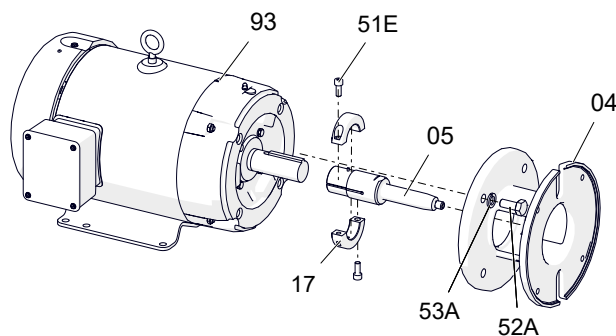

Assembly

ATTENTION



When attaching the new seal, take care to mount the parts and gaskets, both of the stationary part on the cover and the rotating part on the shaft, using soapy water to allow them to slide better.

ATTENTION



Smear the gaskets with soapy water to help them slide more easily.

1. Fit the pump shaft (05) to the motor (93).
2. Fit the shaft retaining ring (17) as shown in Figure 01.030.32.0034, ensuring that the shaft pin (05) aligns with the hole in the retaining ring (17).
3. Lightly tighten the Allen screws (51E) on the clamping ring (17). The pump shaft (05) must be able to move.
4. Fit the lantern ring (04) to the motor and secure it with the screws (52A) and washers (53A).

ATTENTION



Apply assembly lubricant to the thread and the head of the shaft clamping ring bolt (17).

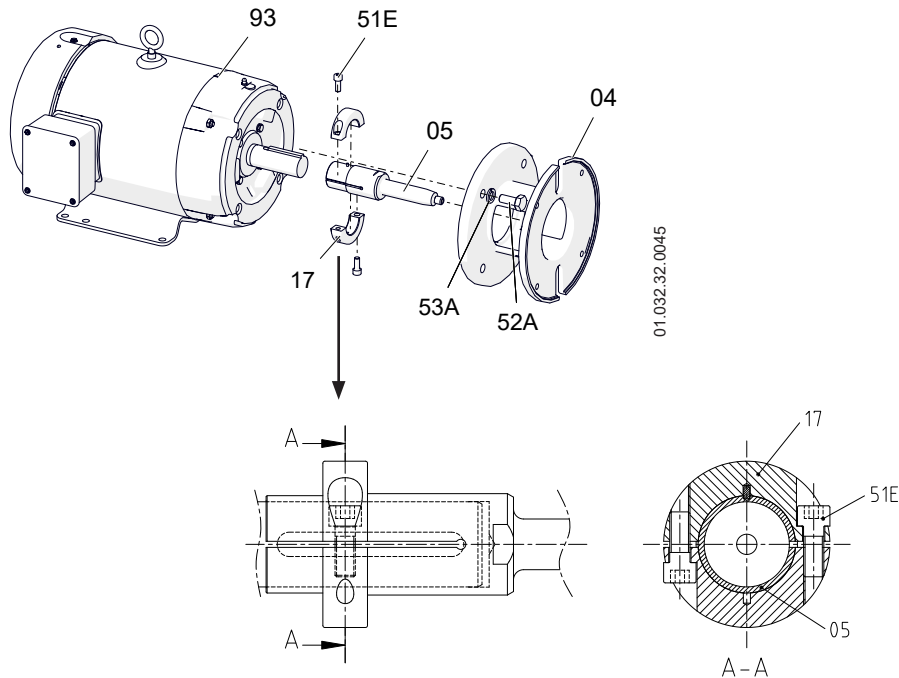

5. Fit the mechanical seal thrust washer (08) to the rear of the pump cover (03). The four tabs that secure the spring should be facing outwards.
6. Position the spring of the mechanical seal (08) over the thrust washer within the centring tabs.
7. Place the mechanical seal cover (09) over the thrust washer and spring assembly located on the pump cover (03), ensuring that the thrust tabs on the seal washer align with their slots, and secure it with the Allen screws (51).

8. Place the pump cover (03) over the lantern (04) and secure it with the screws (52) and washers (53).

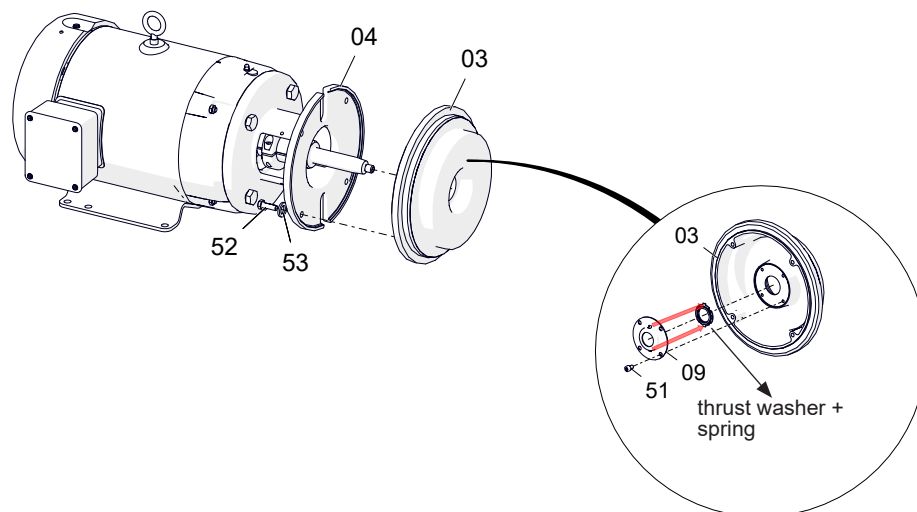

01.032.32.0046

9. Adjust the position of the shaft:
- fit the O-ring (80A) onto the impeller nut (45).
 - fit the impeller (02) onto the pump shaft and secure it with the cap nut (45). To secure the shaft, place a spanner between the flanges.
 - slide the impeller (02) together with the shaft (05) until it comes to rest against the pump cover (03)
 - fit the O-ring (80) onto the pump cover (03).
 - attach the body (01) and secure it with the retaining ring (15).

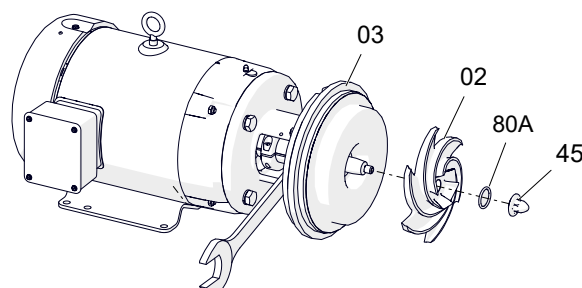

01.032.32.0047

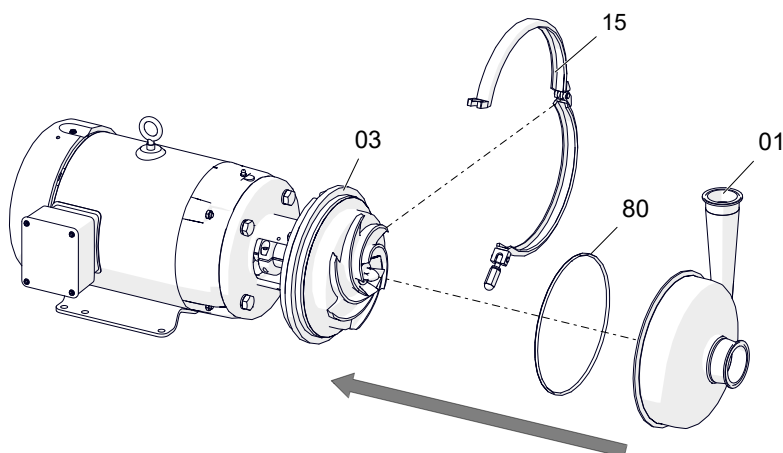

01.032.32.0049

- move the pump shaft so that the impeller is at the required distance B from the pump body (03). To check this distance, a feeler gauge should be used.
- Tighten the Allen screws (51E) on the shaft retaining ring (17).

Pump	ØB [in]
HCPN 40-110	0,016
HCPN 40-150	0,016
HCPN 40-205	0,020
HCPN 50-150	0,016
HCPN 50-190	0,020
HCPN 50-260	0,020
HCPN 65-175	0,016
HCPN 65-215	0,020
HCPN 65-250	0,020
HCPN 80-175	0,016
HCPN 80-205	0,020
HCPN 80-240	0,020

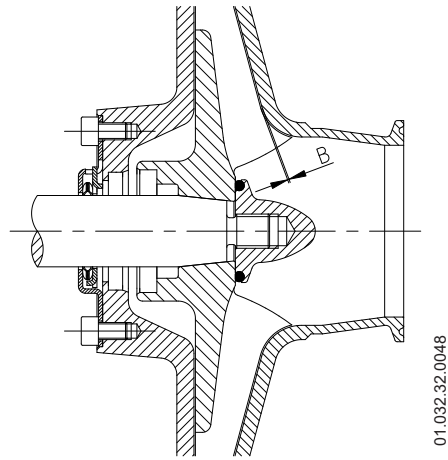

01.032.32.0048

- Remove the pump body (01) and the impeller (02).
10. Fit the stationary part of the mechanical seal (08) onto the pump cover (03), ensuring that the anti-rotation tabs align with the slots in the mechanical seal (08).

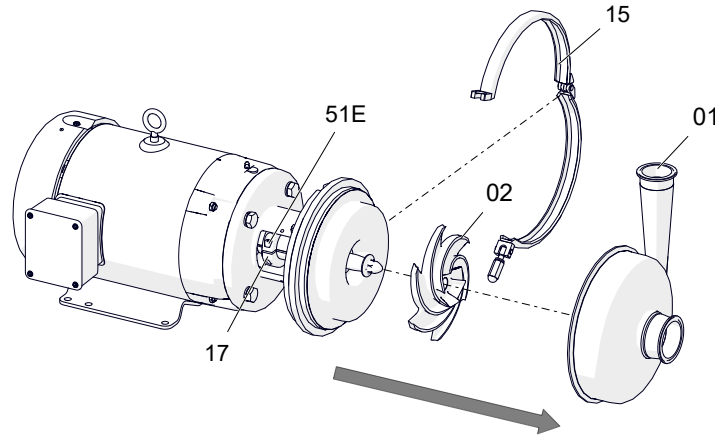

01.032.32.0050

11. Position the rotating part of the mechanical seal (08) at the rear of the impeller (02), ensuring that it is properly aligned.
12. Refit the impeller (02), securing it with the nut (45) and the pump body (01).

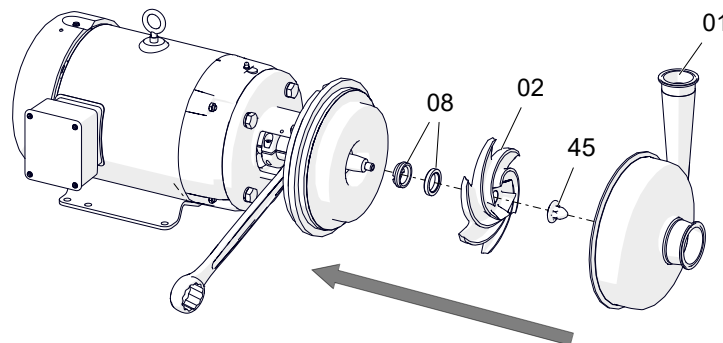

01.032.32.0051

13. Fit the guards (47) and secure them with the flanged screws (50).

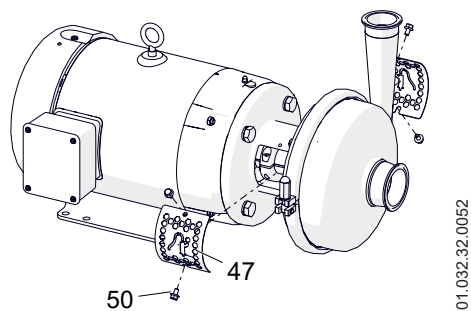

8.7.2. Pump with double mechanical seal

Disassembling

1. Loosen and remove the retaining ring (15) and remove the pump body (01).
2. Remove the O-ring (80) from the pump cover (03). Check its condition and replace it if it is damaged.

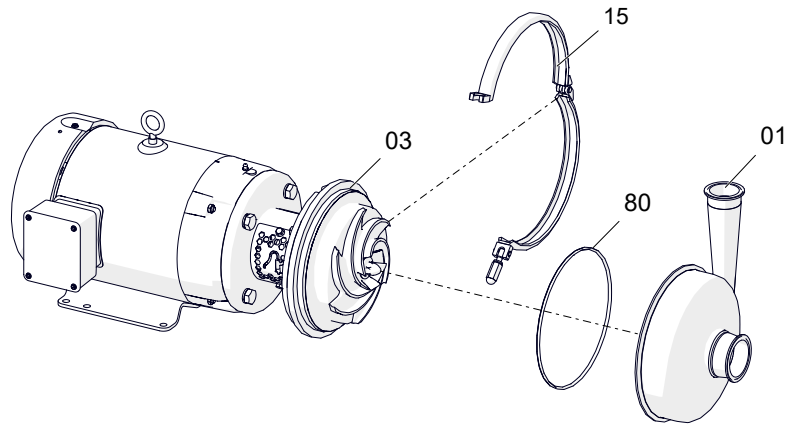

01.032.32.0041

3. Remove the lantern guards (47) by loosening and removing the flanged screws (50).

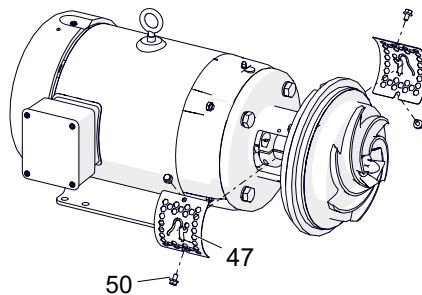

01.032.32.0042

4. Secure the shaft (05) by placing a spanner between the flanges to remove the impeller nut (45).
5. Remove the O-ring (80A) from the impeller nut (45).
6. Remove the impeller (02). If necessary, give it a sharp tap with a rubber mallet to knock the cone loose.
7. Remove the rotating part of the single mechanical seal (08) from the rear of the impeller (02).
8. Remove the stationary part of the single mechanical seal (08) from the pump cover (03).

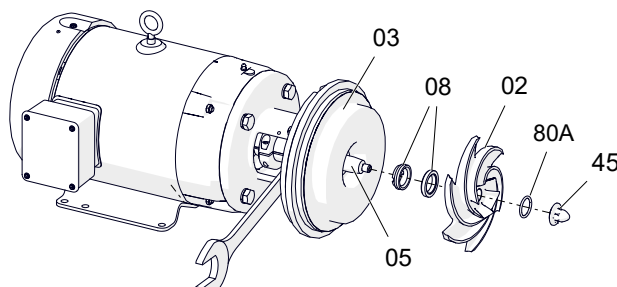

01.032.32.0043

9. Remove the pump cover (03) by loosening and removing the screws (52) and washers (53) that secure it to the lantern (04). Ensure that the stationary part of the secondary mechanical seal (08A), which is housed at the rear of the double mechanical seal cover (10), does not fall out.
10. Remove the stationary part of the secondary mechanical seal (08A) from the cover of the double mechanical seal (10).
11. Remove the cover of the double mechanical seal (10) by loosening the screws (51B).
12. Remove the thrust washers and the spring from the mechanical seals (08, 08A).
13. Remove the O-ring (80C) from the cover of the double mechanical seal (10).
14. Remove the ring from the double mechanical seal (30) by loosening the stud (55).

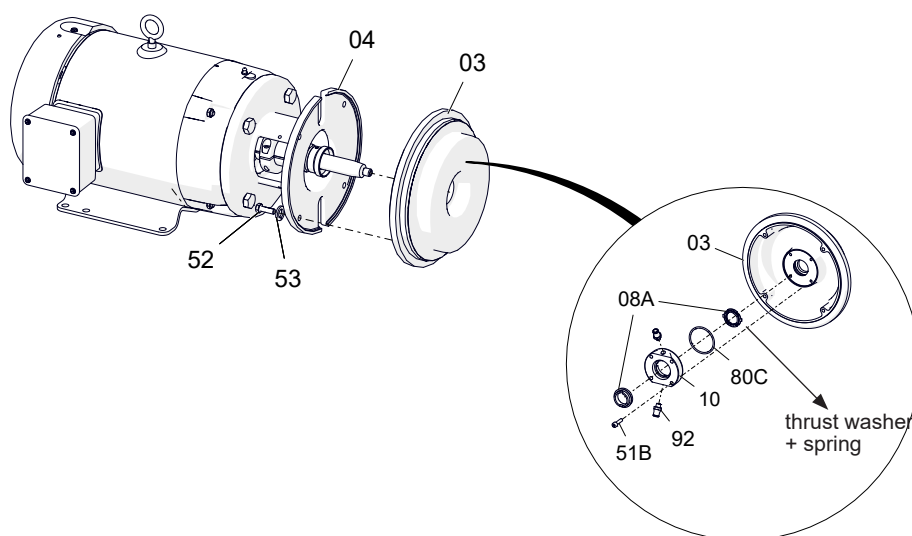

01.032.3.0053

15. Remove the rotating part of the secondary mechanical seal (08A) from the double mechanical seal ring (30).
16. Remove the O-ring (80D) from the double mechanical seal ring (30).
17. Remove the lantern (04) from the pump by loosening and removing the screws (52A) and their washers (53A).
18. Loosen the Allen screws (51E) on the axle clamping ring (17).
19. Remove the pump shaft (05) together with the shaft retaining ring (17).

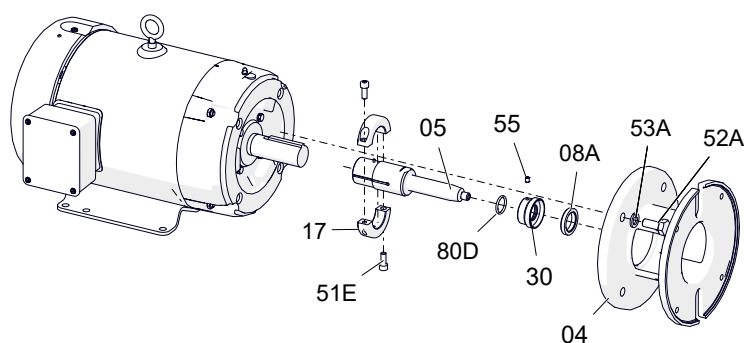

01.032.32.0054

Assembling

ATTENTION



When attaching the new seal, take care to mount the parts and gaskets, both of the stationary part on the cover and the rotating part on the shaft, using soapy water to allow them to slide better.

ATTENTION



Smear the gaskets with soapy water to help them slide more easily.

1. Fit the pump shaft (05) to the motor (93).
2. Fit the shaft retaining ring (17) as shown in Figure 01.030.32.0034, ensuring that the shaft pin (05) aligns with the hole in the retaining ring (17).
3. Lightly tighten the Allen screws (51E) on the clamp. The pump shaft (05) must be able to move.

ATTENTION



Apply assembly lubricant to the thread and the head of the clamp screw.

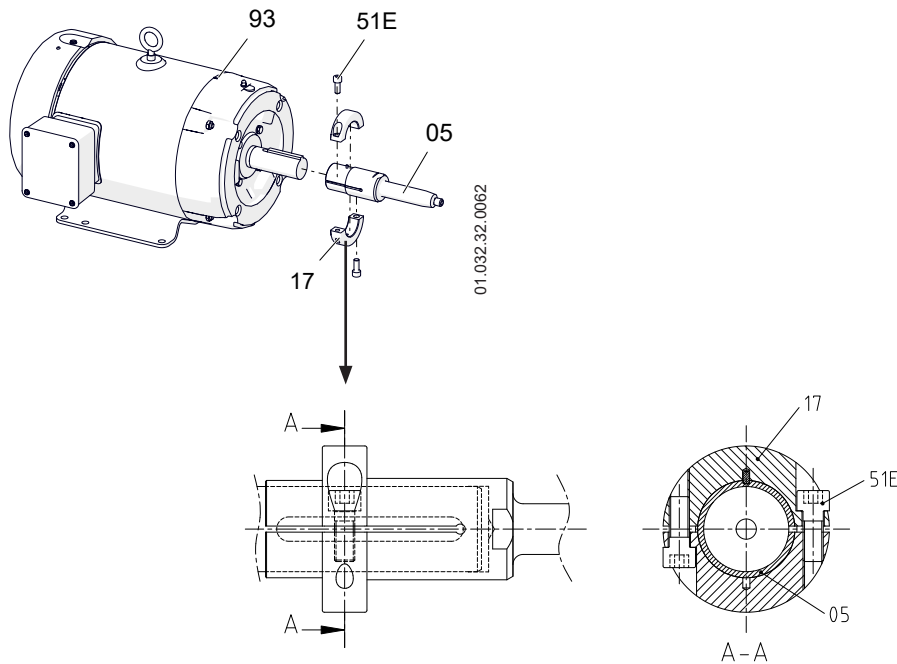

4. Place the O-ring (80D) onto the ring of the double mechanical seal (30).
5. Place the rotating part of the secondary mechanical seal (08A) onto the ring of the double mechanical seal (30).
6. Place the ring of the double mechanical seal (30) with the stud (55) onto the pump shaft (05) without securing it.
7. Fit the lantern (04) to the engine (93) and secure it with the screws (52A) and washers (53A).

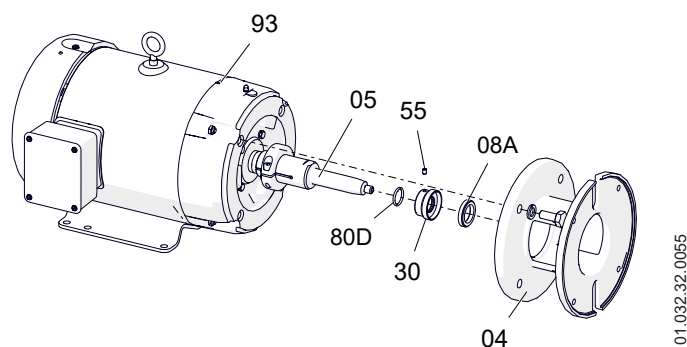

8. Fit the O-ring (80C) onto the cover of the double mechanical seal (10).
9. Place the thrust washer for the single mechanical seal (08) on the pump cover (03). The four tabs that secure the spring should be facing outwards.
10. Position the spring of the single mechanical lock (08) onto the thrust washer within its centring tabs.
11. Place the thrust washer for the secondary mechanical seal (08A) onto the spring of the single mechanical seal (08). The four tabs that secure the spring should face inwards.
12. Fit the double mechanical seal cover (10) onto the pump cover (03) so that the drive tabs on the seal washer align with their slots and the fittings are positioned vertically, then secure it with the screws (51B).
14. Manually position the stationary part of the secondary mechanical seal (08A) onto the cover of the double mechanical seal (10), aligning its grooves with the tabs on the thrust washer of the secondary mechanical seal (08A).
15. Place the pump cover (03) over the lantern (04), taking care not to knock the mechanical seal against the shaft (05), and secure it with the screws (52) and their washers (53).

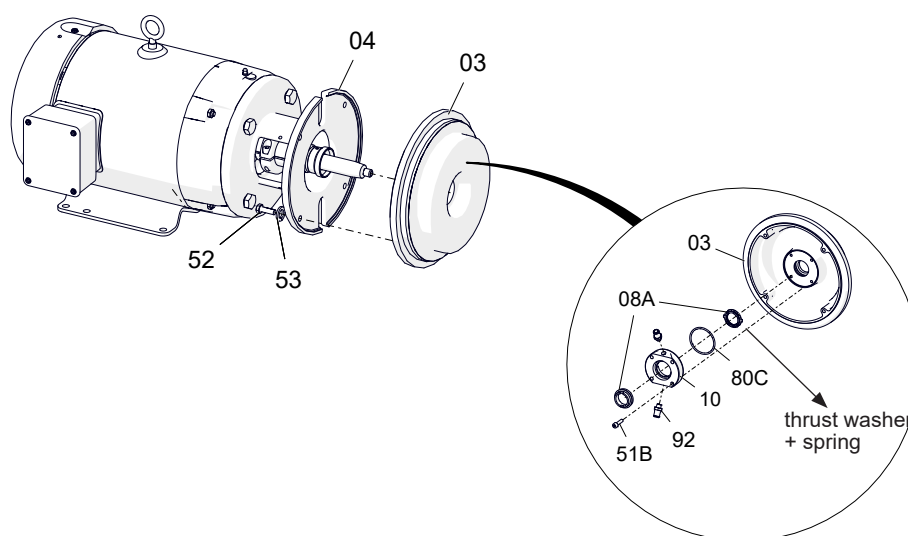

16. Adjust the position of the shaft:
 - fit the O-ring (80A) onto the impeller nut (45).
 - fit the impeller (02) onto the pump shaft and secure it with the cap nut (45). To secure the shaft, place a spanner between the flanges.
 - slide the impeller (02) together with the shaft (05) until it comes to rest against the pump cover (03).
 - fit the O-ring (80) onto the pump cover (03).
 - attach the body (01) and secure it with the retaining ring (15).

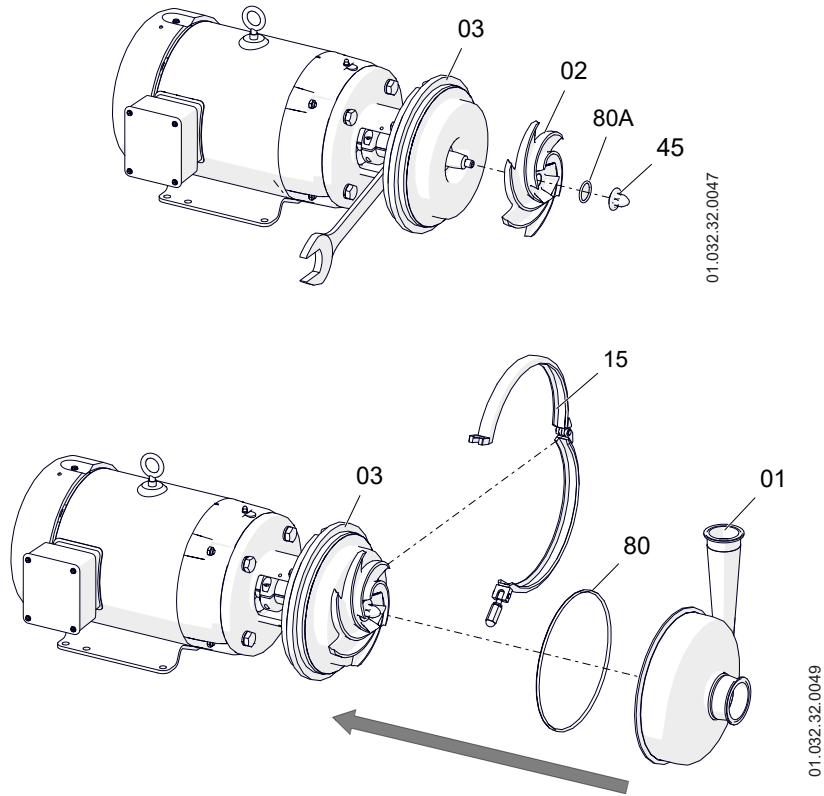

- move the pump shaft so that the impeller is at the required distance B from the pump body (03).

Pump	ØB [in]
HCPN 40-110	0,016
HCPN 40-150	0,016
HCPN 40-205	0,020
HCPN 50-150	0,016
HCPN 50-190	0,020
HCPN 50-260	0,020
HCPN 65-175	0,016
HCPN 65-215	0,020
HCPN 65-250	0,020
HCPN 80-175	0,016
HCPN 80-205	0,020
HCPN 80-240	0,020

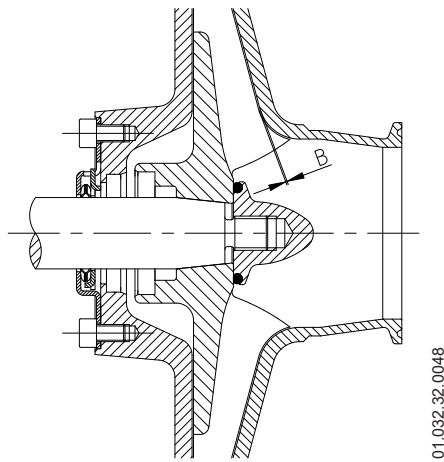

- Tighten the Allen screws (51E) on the shaft retaining ring (17).
- Remove the pump body (01) and the impeller (02).

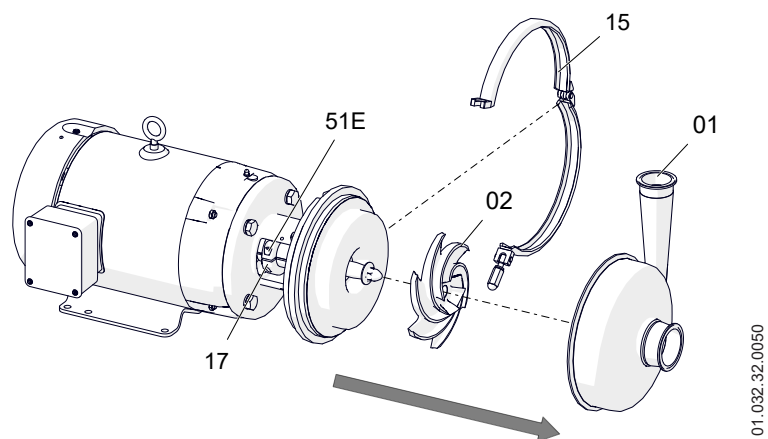

01.032.32.0050

17. Slide the ring of the double mechanical seal (30) onto the shaft (05) and check that the installation dimension A between the ring and the cover of the double mechanical seal is as specified in the table below:

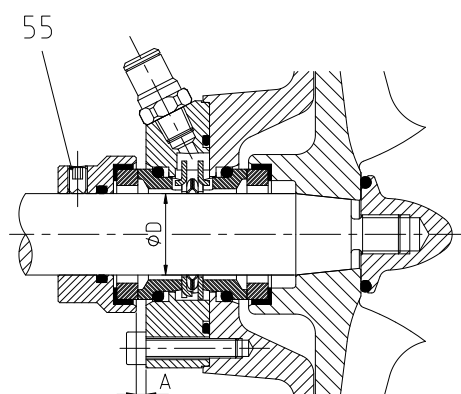

01.030.32.0017

ϕD [in]	A [in]
0,984	0,118
1,378	0,138

18. Tighten the set screw (55) to secure the secondary mechanical seal ring (30).
 19. Fit the stationary part of the single mechanical seal (08) onto the pump cover (03), ensuring that the anti-rotation tabs align with the slots in the single mechanical seal (08).
 20. Position the rotating part of the simple mechanical seal (08) on the rear of the impeller (02), ensuring that it is properly aligned.
 21. Refit the impeller (02) to the pump body (01) using the nut (45).

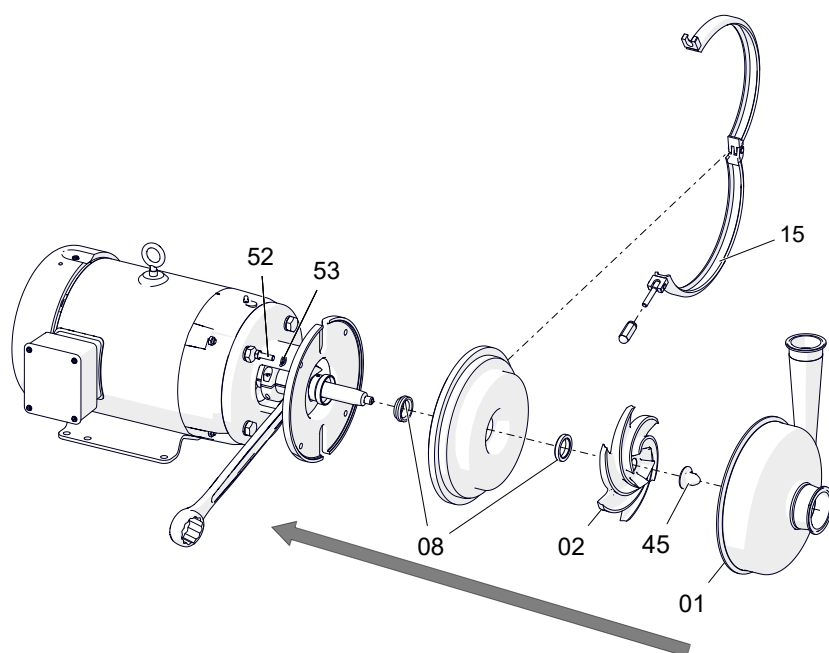

01.032.32.0057

22. Fit the guards (47) and secure them with the flanged screws (50).

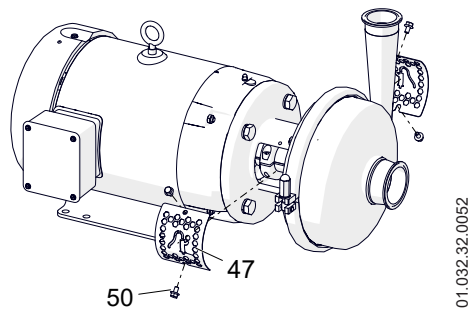

9. Technical Specifications

Maximum working pressure	1600 kPa (16 bar)
Operating temperature range	-10°C to 120°C (EPDM)
Maximum speed	3600 rpm (60 Hz)

Materials

Parts in contact with the product	1.4404 (AISI 316L)
Other stainless steel parts	1.4301 (AISI 304)
Gaskets in contact with the product	EPDM - standard FPM (see other materials)
Other gaskets	NBR
Exterior finish	Matte
Interior finish	polished $Ra \leq 0.8 \mu m$

Cierre mecánico

Type	single or double internal seal, balanced
Stationary part material	graphite (C) – standard silicon carbide (SiC)
Rotating part material	silicon carbide (SiC) - standard
Gasket material	EPDM - standard FPM

Double mechanical seal

Operating pressure	from atmospheric pressure up to 100 kPa (1 bar) above the pump's operating pressure
Consumption of auxiliary fluid	30 l/h

Motor

Type	three-phase asynchronous, NEMA C Face, 2 - or 3 pole, IP55 and class F insulation
Power	0,55 HP to 55 HP
Voltage and frequency	208-230 V / 460 V 60 Hz

9.1. NOISE LEVEL

The figures given apply to the standard pump with the largest impeller at its best efficiency point and fitted with a motor of the required power.

These readings were taken at a distance of 1 m from the pump and at a height of 1.6 m above ground level. The measurements were carried out in accordance with standard EN 12639 / ISO 3746 Grade 3, with a tolerance of ± 3 dB(A).

Pump	Sound pressure LpA dB(A)	Sound power LwA dB(A)
HCPN 40-110	61	74
HCPN 40-150	63	75
HCPN 40-205	70	84
HCPN 50-150	71	84
HCPN 50-190	78	92
HCPN 50-260	70	84
HCPN 65-175	72	85
HCPN 65-215	78	92
HCPN 65-250	79	93

Pump	Sound pressure LpA dB(A)	Sound power LwA dB(A)
HCPN 80-175	77	90
HCPN 80-205	80	94
HCPN 80-240	77	91

It should be noted that noise levels can increase significantly if reducers, fittings or other accessories are installed near the pump.

9.2. WEIGHT

Pump	Weight ¹ [kg]							
	56C	143/145TC	182/184TC	213/215TC	254/256TC	284/286TSC	324/326TSC	405TSC
HCPN 40-110	9	9						
HCPN 40-150	12	12	14					
HCPN 40-205			21	21	22			
HCPN 50-150	12	12	14	14				
HCPN 50-190			21	21	22			
HCPN 50-260				36	37	37	41	
HCPN 65-175				24	25			
HCPN 65-215				29	30	30	34	
HCPN 65-250				35	37	37	40	
HCPN 80-175				24	24	24		
HCPN 80-205				29	29	29	33	
HCPN 80-240				36	37	37	41	41

1) Weight of the pump (excluding the motor)

9.3. DIMENSIONS

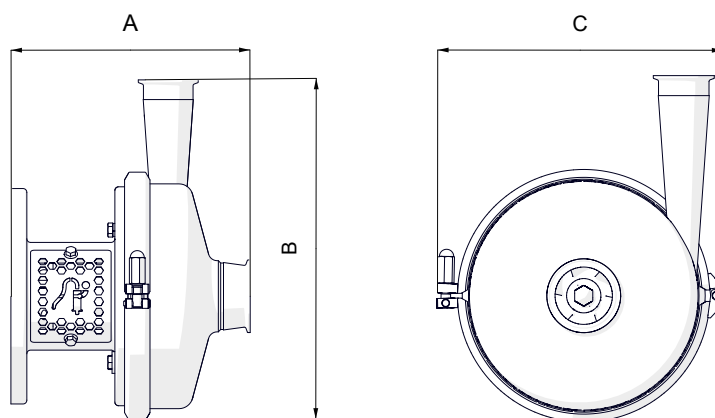

01.032.32.0058 - 01.032.32.0059

Pump	Motor	Dimensions [inches]		
		A	B	C
HCPN 40-110	56C	8,27	8,27	7,48
	143/145TC			
HCPN 40-150	56C	8,46	8,66	9,25
	143/145TC			
	182/184TC			
HCPN 40-205	182/184TC	9,84	12,01	11,81
	213/215TC			
	254/256TC			
HCPN 50-150	56C	8,66	9,84	9,25
	143/145TC			
	182/184TC	10,04	11,81	
	213/215TC			
HCPN 50-190	182/184TC	10,04	13,39	11,81
	213/215TC			
	254/256TC			
HCPN 50-260	213/215TC	11,61	14,96	15,75
	254/256TC			
	284/286TSC	11,22	15,94	
	324/326TSC			
HCPN 65-175	213/215TC	11,22	13,19	11,81
	254/256TC			
HCPN 65-215	213/215TC	11,42	14,76	13,39
	254/256TC			
	284/286TSC	11,22	15,75	
	324/326TSC			
HCPN 65-250	213/215TC	11,42	16,34	15,75
	254/256TC			
	284/286TSC	11,22	17,32	
	324/326/364TSC			
HCPN 80-175	213/215TC	11,61	13,19	11,81
	254/256TC			
	284/286TSC	11,42	14,17	
213/215TC				
HCPN 80-205	254/256TC	12,60	14,57	13,39
	284/286TSC			
	324/326/364TSC	11,81	16,54	
	213/215TC			
HCPN 80-240	213/215TC	12,01	16,73	15,75
	254/256TC			
	284/286TSC	11,81	17,72	
	324/326/364/365TSC			
	405TSC	12,01	18,70	

9.4. EXPLODED VIEW AND PARTS LIST FOR THE PROLAC HCPN PUMP

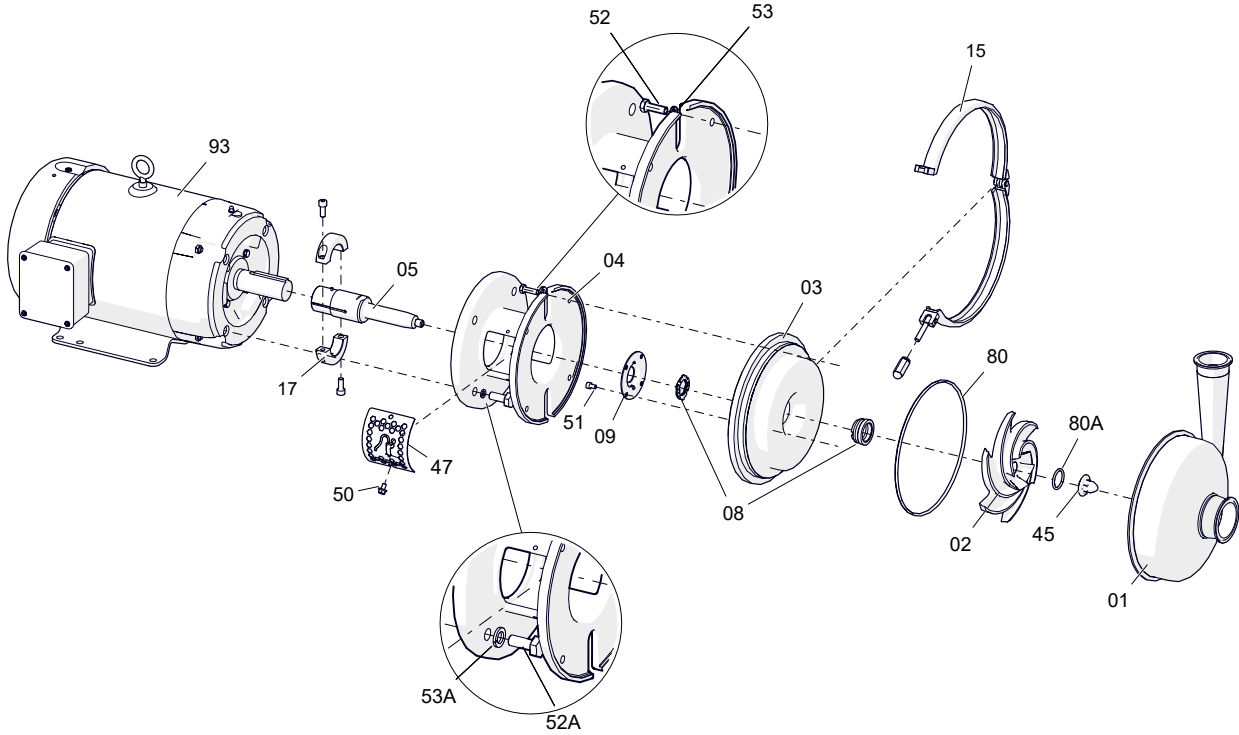

01.032.32.0060

Position	Description	Quantity	Material
01	body	1	1.4404 (AISI 316L)
02	impeller	1	1.4404 (AISI 316L)
03	pump cover	1	1.4404 (AISI 316L)
04	lantern	1	1.4301 (AISI 304)
05	shaft	1	1.4404 (AISI 316L)
08	mechanical seal ¹	1	-
09	mechanical seal cover	1	1.4404 (AISI 316L)
15	body clamp	1	1.4301 (AISI 304)
17	shaft retaining ring	1	1.4301 (AISI 304)
45	impeller nut	1	1.4404 (AISI 316L)
47	lantern protector	2	1.4307 (AISI 304L)
50	flanged screw	4	A2
51	Allen screw	4	A2
52	hexagon bolt	4	A2
52A	hexagon bolt	4	A2
53	grower washer	4	A2
53A	grower washer	4	A2
80	O-ring ¹	1	EPDM
80A	O-ring ¹	1	EPDM
93	motor	1	-

1) Recommended spare parts

9.5. EXPLODED VIEW AND PARTS LIST FOR PROLAC HCPN PUMP WITH DOUBLE MECHANICAL

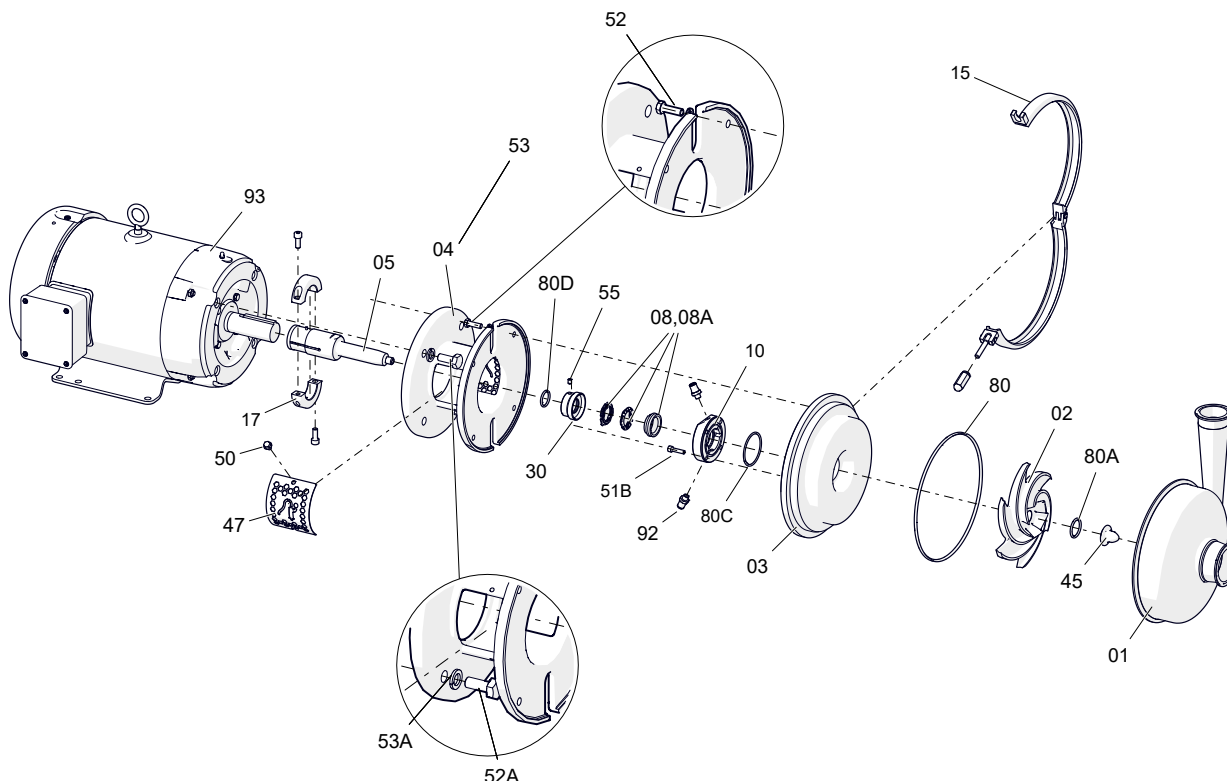

01.032.32.0061

Position	Description	Quantity	Material
01	body	1	1.4404 (AISI 316L)
02	impeller	1	1.4404 (AISI 316L)
03	pump cover	1	1.4404 (AISI 316L)
04	lantern	1	1.4301 (AISI 304)
05	shaft	1	1.4404 (AISI 316L)
08	single mechanical seal ¹	1	-
08A	secondary mechanical seal ¹	1	-
10	double mechanical seal cover	1	1.4404 (AISI 316L)
15	body clamp	1	1.4301 (AISI 304)
17	shaft retaining ring	1	1.4301 (AISI 304)
30	double mechanical seal ring	1	1.4404 (AISI 316L)
45	impeller nut	1	1.4404 (AISI 316L)
47	lantern protector	2	1.4307 (AISI 304L)
50	flanged screw	4	A2
51B	Allen screw	4	A2
52	hexagon bolt	4	A2
52A	hexagon bolt	4	A2
53	grower washer	4	A2
53A	grower washer	4	A2
55	stud	1	A2
80	O-ring ¹	1	EPDM
80A	O-ring ¹	1	EPDM
80C	O-ring ¹	1	EPDM
80D	O-ring ¹	1	EPDM
92	straight connector 1/8" BSPT D.8	2	1.4301 (AISI 304)
93	motor	1	-

1) Recommended spare parts

How to contact INOXPA S.A.U.:

Details for all countries are continuously updated on our website.

Visit www.inoxpa.com to access the information.



INOXPA S.A.U.
Telers, 60 - 17820 - Banyoles - España

